

Rigging

OPERATION - SwiftLift™ Clutches

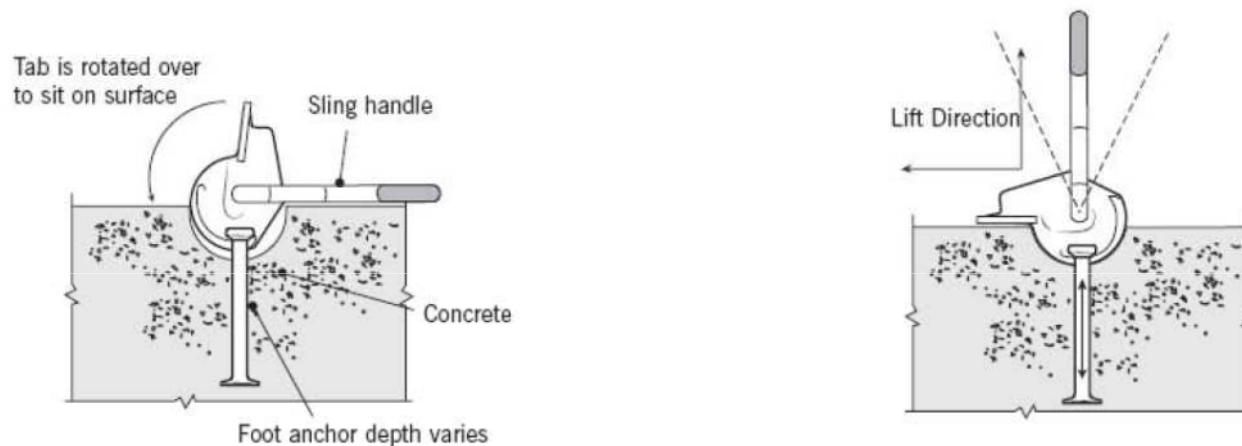

1. SwiftLift Clutch is attached to the SwiftLift anchor by;
 - lowering the clutch slot over the anchor
 - then rotation the clutch tab until it rests on the concrete surface
2. As the load is raised, the anchor takes the full load of tension

Rigging

OPERATION - SwiftLift™ Clutches

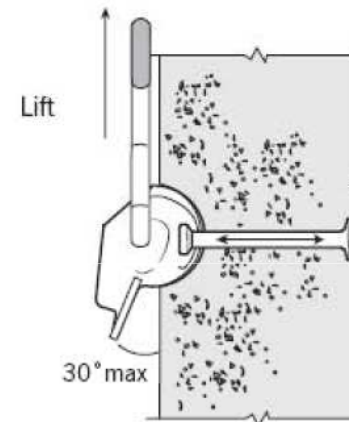
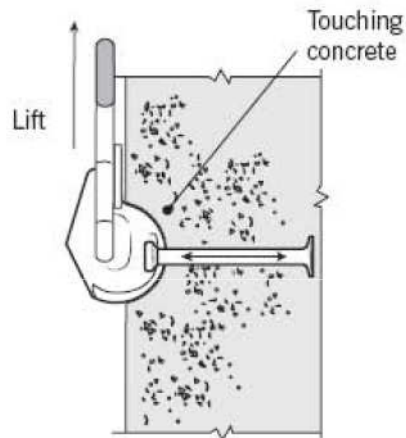

3. As the panel rotates to the vertical position, the clutch comes in contact with the concrete surface;
 - this transfers the lifting force into the concrete
 - the anchor prevents the clutch from slipping out of the void
4. Lifting away from the tab is also safe provided the tab does not rise more than 30° from the concrete surface

Rigging

Check for wear and tare - SwiftLift™ Clutches

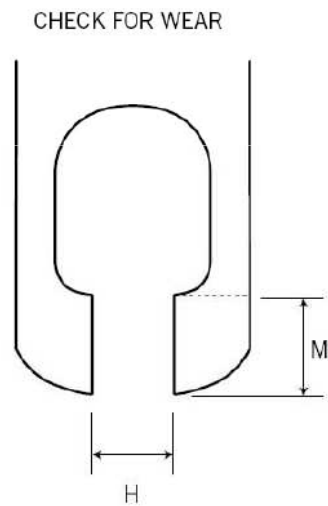
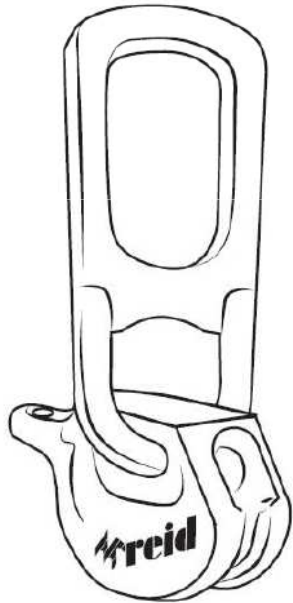

| Size | H max (mm) | H min (mm) |
|------|---------------|---------------|
| 1.3 | 13 | 5.5 |
| 2.5 | 18 | 5.5 |
| 5.0 | 25 | 8.0 |
| 10.0 | 32 | 12.0 |
| 20.0 | 46 | 18.0 |
| 32.0 | 58 | 24.0 |

Rigging

Effective Rigging



Using a triangular spreader beam with shackles and two sets of chains will ensure legs are equally loaded.



Using a spreader beam with two sets of chains will ensure the legs are equally loaded.

Rigging

Effect of sling angle

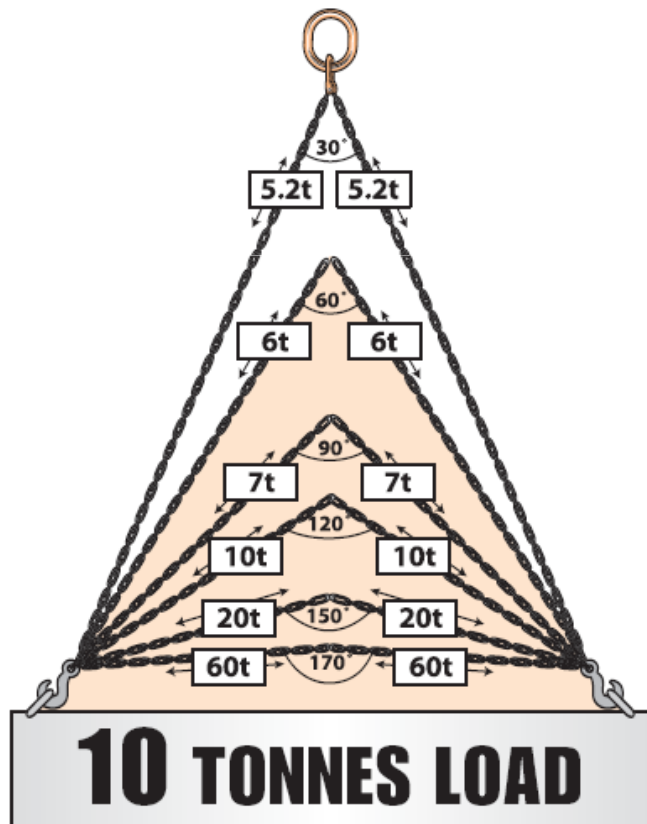

1. The longer the slings. The lower the load on the anchors.
 - For example, at an angle of 170° the load on each sling is six times the weight of the actual load being lifted
2. Never make sling length shorter than the distance between two anchors.
3. Never set the sling up with a greater angle than 60°.

Rigging - Configurations

Fig. 35

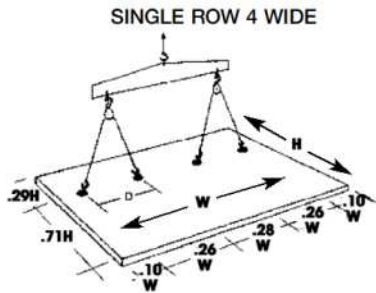
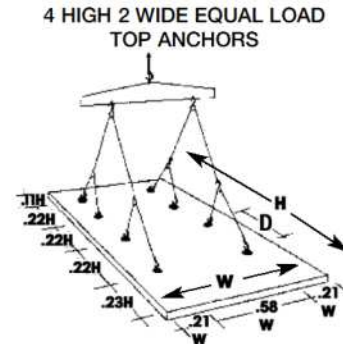
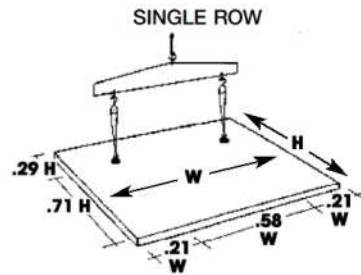
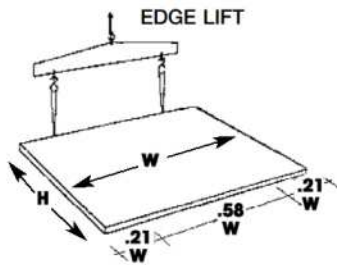

DOUBLE ROW 2 HIGH 2 WIDE

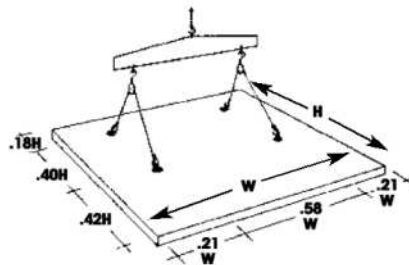

3 HIGH 2 WIDE

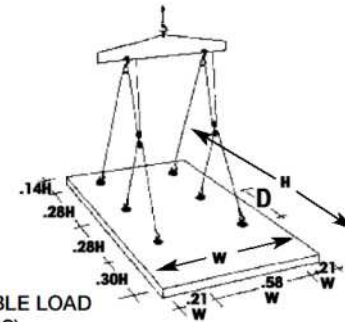

2 HIGH 4 WIDE

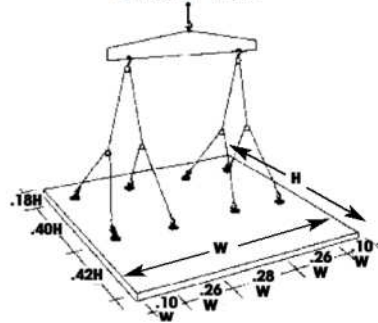

3 HIGH 2 WIDE (DOUBLE LOAD TOP ANCHORS)



Panels with window or door openings, irregular shapes or containing double loaded anchors must be referred to Reid's Engineers for specific design.

